

REPLACE AND NULLIFY THE REV.00

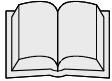

## READ THE USE AND MAINTENANCE HANDBOOK

### PROGRAMMING CONSOLE

#### Console functions

The console is used to:

- set the chopper for customized drive motor operation.
- read alarm types for proper and easy troubleshooting.
- test electrical values and the state of the electric circuit for the drive system.

#### Using the console

The console is very simple to use, comparable to using the most common popular electronic devices (cell phones, for example).

To start the console you must *always comply with* the following sequence of procedures:

1. TURN the main machine key OFF;
2. connect the console to the empty connector. If this connection is not easy then check that the connector is positioned in the proper direction;
3. turn on the key and start to work with the console;
4. exit from all programs (main start-up menu) and TURN the main machine key OFF;
5. disconnect the console connector.

**MISTAKES IN THIS SEQUENCE OF PROCEDURES COULD JEOPARDIZE PROPER OPERATION BY THE CHOPPER OR THE CONSOLE**

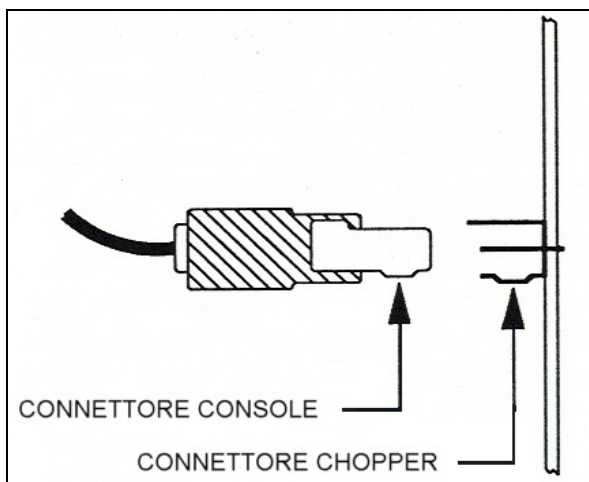

## Console menus

The following figure indicates how to move about in the menus presented by the console and also gives a brief explanation of these (some menus contain only information necessary for correct chopper operation and cannot be modified without authorization from Comac).

Consult the chopper manual for a more detailed description. The following basic notions are given for setting up the machine.

Press ENTER to enter the menu. Use the ROLL key to move about in the menu. Use the PARAM SET key to change already set values. Use the OUT key to exit from a program.

The console, when exiting from a menu, asks for confirmation of changes related to any change introduced inside that menu (ARE YOU SURE? YES=ENTER, NO=OUT).

**HEADING:** here we read the main characteristics of the console and the chopper, the name of the machine to which it is connected, maximum chopper voltage and current, operating hours by the chopper card.

**PROGRAM:** this menu is used to change machine customizing parameters. The parameters you can set as you wish are: CUT BACK SPEED 1 (minimum machine speed) and CUT BACK SPEED 2 (average machine speed). **All other parameters are selected by Comac in function of the type of drive wheel installed. It is forbidden to vary these without authorization from Comac.**

**TESTER:** this menu permits you to read characteristic electric circuit parameters (motor voltage, motor current, state of the power switch = closed/open ...).

**SAVE:** this is used, once parameters have been changed, to record the new set in a memory location in the console. Remember that the console already has, stored, parameter sets (PROGRAM 01 and PROGRAM 02) with correct configurations for the two different drive wheels provided.

**RESTORE:** used to restore, on the chopper, a set of parameters recorded in the console. Standard programs PROGRAM 01 and PROGRAM 02 concern drive wheels for model C130.

**ALARMS:** this indicates the last five alarms that took place on the machine. Corrective action must be taken according to the type of alarm that takes place (see following paragraph).

**PROGRAM VACC:** this section is used to make the chopper recognize the potentiometer that is installed on the machine. **This is a procedure to perform when there is a Vacc not ok alarm, when the potentiometer is replaced or when the chopper is replaced.** A mistake in potentiometer recognition by the chopper will block machine operation.

**MOTOR DATA:** motor characteristic parameterization.

## Console flow diagram

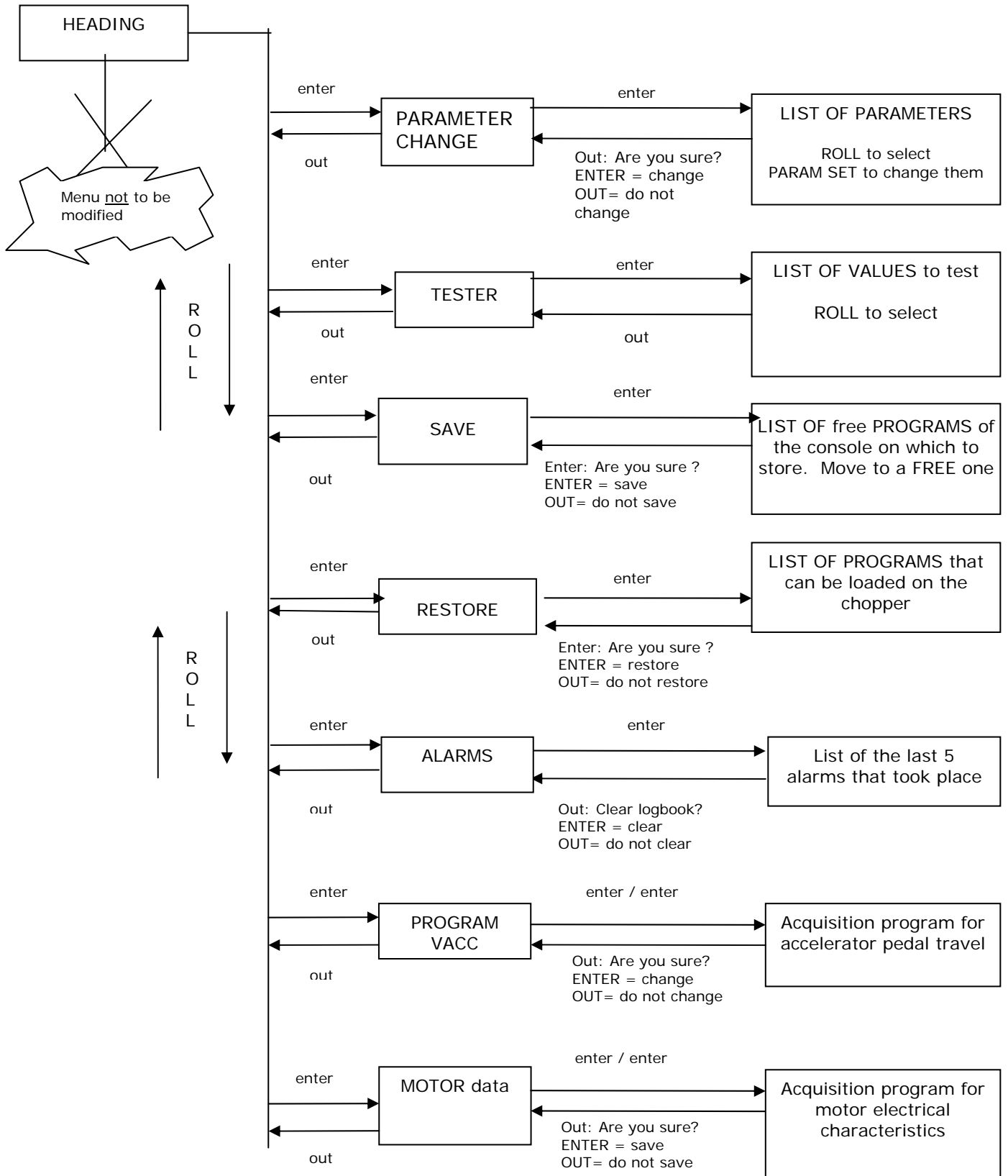

## Alarms and Decodification

The chopper displays a malfunction on two information levels:

1. by a red alarm LED (on the machine dashboard) that flashes a certain number of times depending on the type of malfunction;
2. by a message on the console that gives a more detailed explanation of the type of malfunction.

The following table gives, for every alarm, the possible malfunction and the measures to be taken on the machine.

### ALARM DIAGNOSIS TABLE

(to further comprehend the table refer to the machine's wiring diagram, dwg. 18.51.11 rev03)

Number of flashes	MESSAGE	NOTES
1	EEPROM DATA KO	Breakdown in the memory area containing hour counter, motor and stored alarm data. The alarm blocks the machine.  <u>Corrective actions:</u> - turn the key on and off. Replace the chopper if the problem persists.
1	EEPROM PAR. KO	The chopper memory has lost adjustment parameter data.  <u>Corrective actions:</u> - turn the key on and off. Replace the chopper if the problem persists. If the alarm disappears then reprogram the chopper (previously stored parameters have been cancelled and replaced by default values).
1	EEPROM CONF. KO	The chopper memory has lost special configuration data.  <u>Corrective actions:</u> - reconfigure the chopper (refer to the console manual); - turn the key on and off. Replace the chopper if the problem persists. If the alarm disappears then reprogram the chopper (previously stored parameters have been cancelled and replaced by default values).
1	EEPROM KO	The chopper memory has lost operating and adjustment data.  <u>Possible causes:</u> - chopper logic is damaged.  <u>Corrective actions:</u> - replace the chopper.

Number of flashes	MESSAGE	NOTES
1	<b>CHOPPER NO CONF.</b>	<p>Chopper logic is not configured.</p> <p><u>Corrective actions:</u></p> <ul style="list-style-type: none"> <li>- check chopper model and inputs (see the console model).</li> </ul>
1	<b>WATCH-DOG</b>	<p>Malfunctions in chopper autotesting either when at rest or during operation.</p> <p><u>Possible causes:</u></p> <ul style="list-style-type: none"> <li>- broken current sensor inside the chopper;</li> <li>- damaged chopper logic.</li> </ul> <p><u>Corrective actions:</u></p> <ul style="list-style-type: none"> <li>- replace the chopper.</li> </ul>
2	<b>INCORRECT START</b>	<p>Mistaken start-up sequence.</p> <p><u>Possible causes:</u></p> <ul style="list-style-type: none"> <li>- error in the sequence performed by the operator;</li> <li>- pedal microswitch and/or operating microswitch are stuck;</li> <li>- wiring error.</li> </ul> <p><u>Corrective actions</u></p> <ul style="list-style-type: none"> <li>- check that the start-up sequence is as follows: <ul style="list-style-type: none"> <li>▪ sit on the machine to close the seat microswitch;</li> <li>▪ turn on the key;</li> <li>▪ select the gear (forward/reverse);</li> <li>▪ press the accelerator;</li> </ul> </li> <li>- check that start command microswitch No. 12 and the operating joystick do not have stuck contacts and that they operate properly;</li> <li>- check continuity of the circuit that connects the start pedal microswitch, the chopper and the start joystick;</li> <li>- if nothing is abnormal and the problem persists then replace the chopper.</li> </ul>
3	<b>NO FULL COND.</b>	<p>This test is performed during full machine operation and checks that VMN is less than 1/3 Vbatt.</p> <p><u>Possible causes:</u></p> <ul style="list-style-type: none"> <li>- malfunction in the diagnosis circuit;</li> <li>- operation blocked.</li> </ul> <p><u>Corrective actions:</u></p> <ul style="list-style-type: none"> <li>- check that motor's negative voltage is less than 1/3 Vbatt;</li> <li>- replace the logic if the defect persists.</li> </ul>

Number of flashes	MESSAGE	NOTES
3	VMN BACK LOW	<p>The chopper tests if, at rest, reverse operation voltage VMN (terminal 3 on the chopper) is approximately 1/2 of the battery voltage. The alarm state is activated if it is not and if it is less than 1/3.</p> <p><u>Possible causes:</u></p> <ul style="list-style-type: none"> <li>- mistaking wiring;</li> <li>- motor leakage to the casing;</li> <li>- stuck contacts;</li> <li>- broken chopper.</li> </ul> <p><u>Corrective actions:</u></p> <ul style="list-style-type: none"> <li>- check that wires 9-10 are correctly connected and that chopper terminal connections and motor field terminal connections are tight (also refer to the following paragraph);</li> <li>- check for short circuits or leaks;</li> <li>- check that microswitches do not have stuck contacts and that they operate properly;</li> <li>- replace the chopper if the problem persists.</li> </ul>
3	VMN FORW LOW	<p>The chopper tests if, at rest, forward operation voltage VMN (terminal 2 on the chopper) is approximately 1/2 of the battery voltage. The alarm state is activated if it is not and if it is less than 1/3.</p> <p><u>Possible causes:</u></p> <ul style="list-style-type: none"> <li>- mistaking wiring;</li> <li>- motor leakage to the casing;</li> <li>- stuck contacts;</li> <li>- broken chopper.</li> </ul> <p><u>Corrective actions:</u></p> <ul style="list-style-type: none"> <li>- check that wires 9-10 are correctly connected and that chopper terminal connections and motor field terminal connections are tight (also refer to the following paragraph);</li> <li>- check for short circuits or leaks;</li> <li>- check that microswitches do not have stuck contacts and that they operate properly;</li> <li>- replace the chopper if the problem persists.</li> </ul>

Number of flashes	MESSAGE	NOTES
4	VACC NOT OK	<p>The chopper tests if accelerator voltage, at rest, is less than the minimum value registered in the memory with the PROGRAM VACC function. The alarm state is activated if it is greater by more than 1 Volt.</p> <p><u>Possible causes:</u></p> <ul style="list-style-type: none"> <li>- broken potentiometer wire;</li> <li>- the potentiometer is incorrectly set;</li> <li>- the potentiometer is damaged.</li> </ul> <p><u>Corrective actions:</u></p> <ul style="list-style-type: none"> <li>- check continuity of connections between potentiometer, accelerator and chopper;</li> <li>- reprogram the chopper with the PROGRAM VACC (see adjustments and testing chapter);</li> <li>- check the efficiency of the potentiometer (it could be broken) and replace it if necessary (and then reprogram the chopper).</li> </ul>
5	I HIGH AT STAND	<p>The chopper tests, if at rest and with remote control switches open, the current signal is null. If it is not the machine enters an alarm state and operation is blocked.</p> <p><u>Possible causes:</u></p> <ul style="list-style-type: none"> <li>- mistaken load connected from the drive motor to terminal 1 of the chopper;</li> <li>- current sensor does not operate;</li> <li>- damaged logic.</li> </ul> <p><u>Corrective actions:</u></p> <ul style="list-style-type: none"> <li>- replace the chopper;</li> <li>- replace the drive wheel if the problem persists.</li> </ul>
5	I=0 EVER	<p>The chopper tests if, when operating, current is greater than a minimum value. If it is not the machine enters an alarm state and operation is blocked.</p> <p><u>Possible causes:</u></p> <ul style="list-style-type: none"> <li>- mistaken wiring between the drive wheel and the chopper;</li> <li>- motor resistance is too high because of a motor defect;</li> <li>- the current sensor is broken.</li> </ul> <p><u>Corrective actions:</u></p> <ul style="list-style-type: none"> <li>- check correct wiring of motor cables on the chopper (the rotor may be connected to terminal +B of the chopper rather than terminal 1);</li> <li>- replace the motor;</li> <li>- replace the chopper if the problem persists.</li> </ul>

Number of flashes	MESSAGE	NOTES
6	CONTACTOR DRIVER	<p>The chopper tests, both when at rest and during operation, that voltage on the drivers that control the remote control switches have values coherent with the state of operation (high if at rest, low with remote control switch energized). Check, using the console tester function, which of the two drivers T1 and T2 is not in a correct state: (Ø) during operation (VB) when at rest.</p> <p><u>Possible causes:</u></p> <ul style="list-style-type: none"> <li>- external short circuit towards -Batt of the wiring that exits from NT1 (E8, pilot of the double forward gear remote control switch) or NT2 (E3, pilot of the double reverse gear remote control switch);</li> <li>- driver breakage because of an overload or short circuit to +Batt of wiring NT1 or NT2;</li> </ul> <p><u>Corrective actions:</u></p> <ul style="list-style-type: none"> <li>- remove the cause and replace the chopper.</li> </ul>
7	TH. PROTECTION	<p>The chopper works at temperatures lower than 75°. When this value is exceeded the maximum current is gradually reduced down to a null value when it reaches 85°.</p> <p><u>Possible causes:</u></p> <ul style="list-style-type: none"> <li>- if the alarm takes place at room temperature (<math>\pm 20^\circ</math>): <ul style="list-style-type: none"> <li>▪ broken cutout sensor;</li> <li>▪ broken power connection;</li> <li>▪ broken chopper;</li> <li>▪ chopper malfunction;</li> <li>▪ machine with brakes blocked;</li> </ul> </li> <li>- very heavy work load with high room temperatures;</li> <li>- insufficient heat dispersion.</li> </ul> <p><u>Corrective actions:</u></p> <ul style="list-style-type: none"> <li>- check cutout sensor connection inside the chopper;</li> <li>- check motor connections;</li> <li>- check machine brakes;</li> <li>- let the chopper rest and cool down;</li> <li>- replace the chopper if the problem persists.</li> </ul>



Number of flashes	MESSAGE	NOTES
8	CONT. DONT CLOSE	<p>Test performed when operation is requested: checks that the remote control switch closes, checking that the motor's negative voltage becomes more than 2/3 Vbatt; enters an alarm state if this does not happen.</p> <p><u>Possible causes:</u></p> <ul style="list-style-type: none"> <li>- main or operating remote control switch broken or disconnected, isolated contacts;</li> <li>- isolated or broken motor;</li> <li>- chopper power broken;</li> </ul> <p><u>Corrective actions:</u></p> <ul style="list-style-type: none"> <li>- check connection cables to the remote control switch and the motor;</li> <li>- replace the chopper.</li> </ul>
CONTINUOUS FLASHING	BATTERY	<p>Machine operation is blocked.</p> <p><u>Cause:</u></p> <ul style="list-style-type: none"> <li>- battery is discharged;</li> <li>- maximum current is reduced by 50%.</li> </ul> <p><u>Corrective actions:</u></p> <ul style="list-style-type: none"> <li>- check the battery charge;</li> <li>- repeat start command to try to start up again.</li> </ul>
CONSTANTLY ON	FORW BACK	<p>This test is always performed. It gives an alarm state when two start commands are present simultaneously.</p> <p><u>Possible causes:</u></p> <ul style="list-style-type: none"> <li>- defective wiring;</li> <li>- start microswitch stuck;</li> <li>- connection to NT1 (E8) broken;</li> </ul> <p><u>Corrective actions:</u></p> <ul style="list-style-type: none"> <li>- Check that start command microswitch No. 12 and operating joystick do not have stuck contacts and that they operate properly;</li> <li>- check connections between start pedal, start joystick, chopper and seat microswitch;</li> <li>- replace the chopper if the defect persists.</li> </ul>

## Drive wheel adjustments and settings

CFR

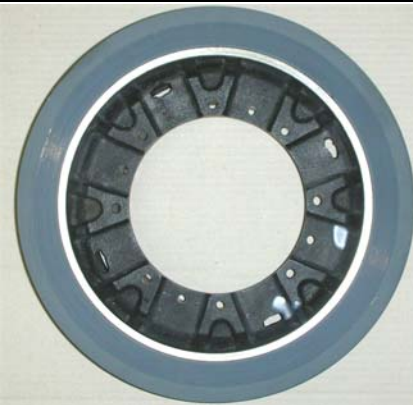
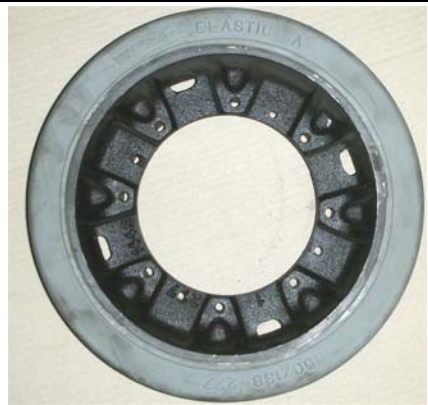
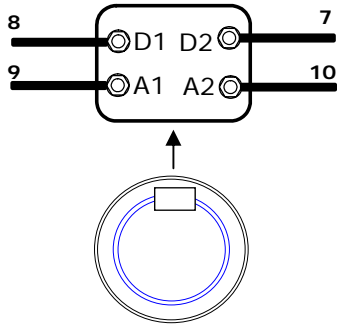

CIMA

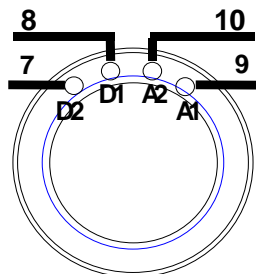

**WARNING** : Invert wires 7 and 8 when operating direction is mistaken.

## CHOPPER ZAPIMOS H1DN

PARAMETERS		CIMA Program <i>PROGRAM 01</i>	CFR Program <i>PROGRAM 02</i>
		VALUE	VALUE
ACCELERATION DELAY	ACCELERAZIONE	5	5
BRAKING	FRENATURA	2	4
CUTBACK SPEED 1	RIDUZIONE VELOCITÀ 1	3	3
CUTBACK SPEED 2	RIDUZIONE VELOCITÀ 2	6	6
COMPENSATION	COMPENSAZIONE	9	9
IMAX	CORRENTE MASSIMA	5	5
BRAKING SPEED	VELOCITÀ FRENATURA	5	5
SPEED LIMIT BRAKING	LIMITE VEL. FRENATURA	5	5
RELEASE BRAKING	FRENATURA A RILASCIO	2	5
MAX SPEED FORWARD	VELOCITÀ MAX AVANTI	9	8
MAX SPEED BACKWARD	VELOCITÀ MAX INDIETRO	8	6
CREEP SPEED	MINIMA VELOCITÀ	1	1
BRAKING TIME	TEMPO DI FRENATURA	5	5

### Adjustment using the console

#### Inserting the console

1. Check that all switches are off.
2. Lift the front wheel on the safety stand.
3. Insert the console into its connector **with the key off.**
4. Turn on using the key.
5. Either "**ZAPI V.2.4 H1 4C.T 0**" or "**\*Alarm\* abcdef ...**" will appear when it starts up
6. Press seat.
7. Press *ENTER* to access the main menu.

#### Programming the chopper

#### Console Display

1. Press *ENTER* to access the main menu.
2. The first item appears: "PROGRAM" = CHANGE PARAMETERS.
3. Press *ENTER* and check, scrolling with *ROLL*, if programming values comply with the previous table.
4. At the end press *OUT* and confirm with *ENTER* (in reply to "DO YOU WANT TO SAVE DATA?") if a parameter has been changed (using the PARAM SET push-buttons on the console).

\* **SELECT MENU** \*

**1- PROGRAM**

**WARNING: SAFETY PARAMETERS CANNOT BE VARIED, SUCH AS ACCELERATION, BRAKING, ETC. ONLY SPEED CUTBACKS CAN BE VARIED (CUTBACK SPEEDS 1 AND 2).**

5. If the chopper memory is lost use <i>ROLL</i> to select "RESTORE" = REPROGRAM CHOPPER PARAMETERS:	* <b>SELECT MENU</b> * <b>4- RESTORE</b>
6. Press <i>ENTER</i> .	
7. The PROGRAM 01 code appears (use <i>ROLL</i> to select the desired PROGRAM):	* <b>SELECT PROGRAM</b> * <b>PROGRAM 01</b>
8. Press <i>ENTER</i> to confirm loading the program.	
9. A request for confirmation appears, press <i>ENTER</i> = YES, <i>OUT</i> = NO :	<b>ARE YOU SURE?</b>
10. Press <i>ENTER</i> to confirm the loading procedure.	
11. The stand-by message appears while loading the parameters:	<b>WAIT!</b>
12. At the end the following message returns:	* <b>SELECT MENU</b> * <b>4- RESTORE</b>

Acquiring accelerator pedal travel	Console Display
1. Use <i>ROLL</i> to select:	* <b>SELECT MENU</b> * <b>6- PROGRAM VACC</b>
2. Press <i>ENTER</i> to display:	<b>FORW</b> <b>BACK</b> <b>4.99</b> <b>4.99</b>
3. Press <i>ENTER</i> to zero the values:	<b>FORW</b> <b>BACK</b> <b>0.0</b> <b>0.0</b>
3. Engage the 3 <sup>rd</sup> forward gear and slowly press the pedal all the way down without stopping and values of the following type will appear:	<b>FORW</b> <b>BACK</b> <b>4.84</b> <b>0.0</b>
4. Repeat the procedure with reverse gear:	<b>FORW</b> <b>BACK</b> <b>4.84</b> <b>4.84</b>
5. Press <i>ENTER</i> to display:	<b>ARE YOU</b> <b>SURE?</b>
6. Press <i>ENTER</i> to confirm and go back to the initial heading:	* <b>SELECT MENU</b> * <b>6- PROGRAM VACC</b>

Tester	
1. <b>WARNING: make sure the front wheel is lifted on the safety stand.</b>	
2. Use <i>ROLL</i> to select:	* <b>SELECT MENU</b> * <b>2- TESTER</b>
3. Press <i>ENTER</i> and various parameters of the following types appear:	<b>VMN</b> <b>VMN &gt; 30%</b>
4. Use <i>ROLL</i> to select:	<b>BATTERY</b> <b>VOLT=36                      36V</b>
5. Use <i>ROLL</i> to select:	<b>MOTOR VOLTAGE</b> <b>VOLT = 00.0</b>
6. Engage forward gear and 3 <sup>rd</sup> gear and the following will appear:	<b>MOTOR VOLTAGE</b> <b>VOLT = 25 – 28</b>
7. Select 2 <sup>nd</sup> gear and rotate the wheel at maximum speed and the following will appear:	<b>MOTOR VOLTAGE</b> <b>VOLT = 19 - 21</b>

<b>Tester</b>	
8. Select 1 <sup>st</sup> gear and rotate the wheel at maximum speed and the following should appear:	<b>MOTOR VOLTAGE VOLT = 11 - 13</b>
9. If speed cutbacks are inverted check the position of the blue and brown wires on the speed switch: the blue wire must be behind the brown wire.	
10. Engage reverse gear select 2 <sup>nd</sup> gear, press the pedal all the way down and the following will appear:	<b>MOTOR VOLTAGE VOLT = 19 - 21</b>
11. Engage reverse gear select 1 <sup>st</sup> gear, press the pedal all the way down and the following will appear:	<b>MOTOR VOLTAGE VOLT = 11 - 13</b>
12. Press <i>OUT</i> .	
10. If necessary select with <i>ROLL</i> :	<b>* SELECT MENU * 1- PROGRAM</b>
12. Turn off the main key and detach the outlet from the chopper console.	
13. Remove the safety stand.	

<b>Motor data</b>	
1. Use <i>ROLL</i> to select:	<b>* SELECT MENU * 7- MOTOR DATA</b>
2. Press <i>ENTER</i> to access the "MOTOR DATA" = ACQUIRE DRIVE MOTOR DATA function. If the value "50" appears then things are correct. Otherwise you can re-program to approach "50" by pressing the brake more or less the moment this is requested by the chopper.	<b>BLOCK MOTOR PLEASE</b>
3. Press <i>ENTER</i> to prepare the acquisition procedure.	
4. Press the brake pedal and keep it pressed. Press <i>ENTER</i> to display:	<b>INSERT FORWARD DIRECTION</b>
5. Engage forward gear with the joystick and press the drive pedal all the way down (at this time the machine should not move).	
6. Press <i>OUT</i> and the following will appear:	<b>ARE YOU SURE?</b>
7. Press <i>ENTER</i> and the following will appear:	<b>WAIT!</b>
8. Press <i>OUT</i> to completely exit from programming mode.	
9. Turn the main key off.	



ADJUSTMENTS  
AND  
TESTING

C130BS

Doc. 10006546  
Issued 06/2007  
Rev. 01  
Page 15 of 25

10. Detach the console outlet from the chopper.

**Testing the efficiency of the Electric System**

1. Detach the battery connector.
2. Check that battery connection cable are clean and tight.
3. Check that power cables are tightly connected: **remote control switches, fuses**, motors, etc.
4. Reconnect the battery connector.
5. Turn the key to start the machine and check that the alarm **signal lamps** flash 5 times.
6. Check signal lamps and switches:
  - check green ignition signal lamp;
  - check that the horn operates properly;
  - check that the hour counter operates properly;
  - check that the front and rear lights operate and that their signal lamp/switch operates;
  - check that the flashing light and its signal lamp operate;
  - check the red parking brake signal lamp;
  - check the red oil level signal lamp;
  - check that the battery test display operates properly;
  - check the solution tank on-reserve float signal lamp;
  - check the red recovery tank signal lamp and that it causes the suction motor to turn off;
  - check the green squeegee lowered signal lamp;
  - check the orange squeegee lift – lower signal lamp;
  - check the green sweeping unit lowered signal lamp;
  - check the orange sweeping unit lift – lower signal lamp;
  - check the solenoid valve and its green signal lamp (with machine and brush motor operating);
  - check the orange sideways base movement signal lamp;
  - check the green complete base retraction signal lamp;
  - check the orange base lift – lower signal lamp;
  - check AUT – MAN operation related to squeegee and suction motor drives;
  - check suction motor operation and signal lamp/switch (with forward gear engaged);
  - check sweeping unit operation and signal lamp/switch (with unit lowered);
  - check solenoid valve operation and signal lamp/switch;
  - check brush motor operation and signal lamp/switch (with base lowered);
  - check sweeping unit AUT – MAN operation (with sweeping unit switch on and forward gear engaged);
  - check the efficiency of the sweeping unit lift – lower and squeegee unit lift – lower joystick;
  - check the efficiency of the base lift – lower and right-left sideways movement joystick;
  - check the efficiency of the forward – reverse gear joystick;
  - check the efficiency of the seat microswitch.

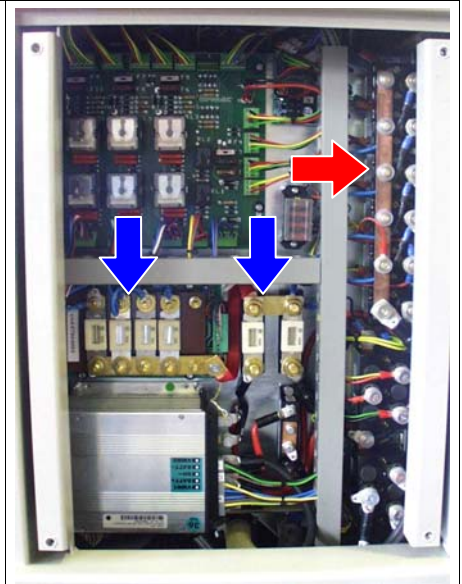



1. Check-up the right set-up of the battery check card. The adjustment can be performed by **microswitches**.
2. The possibles configurations are the following:

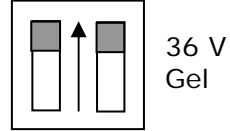
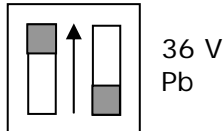
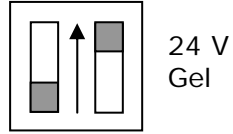
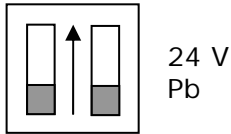

The right configuration is one of the two below, depending on the battery type.

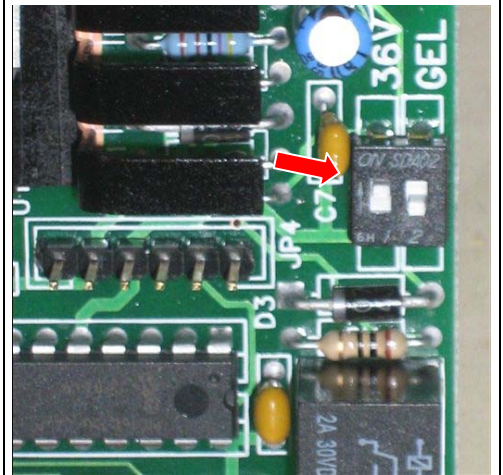
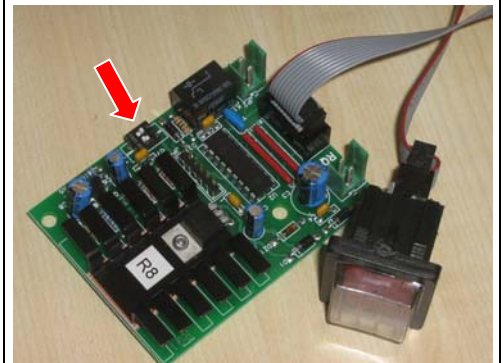

### Adjusting base microswitches

1. Remove the front cover from the machine (casing).
2. Remove the brushes.
3. Adjust the base lift support wheels: lower the base and clamp the bracket fastening screws so that the outside diameter of the **small wheel is 30-32 mm** from the lower part of the frame.

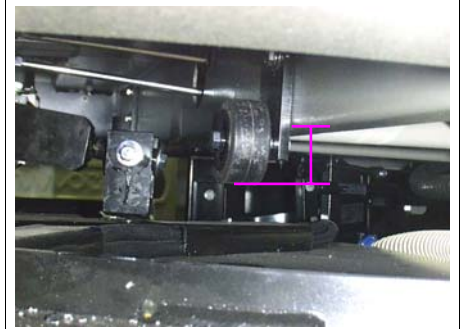

4. Adjust **dowel M10** in order to achieve maximum base lift: the gas springs, when they are all compressed, must still have about 5-8 mm of stem exposed.
5. Tighten the lock nut.



6. Remove the microswitch cover from the jack.
7. Actuate lifting until the jack is totally closed. Advance the travel stop 2-3 mm by adjusting the cam of the **lift microswitch** (the central one) so that the joint **fastening screw** (visible by dismantling the footrest platform) remain 2-3 mm. distant from the frame.
8. Actuate lowering until maximum extension of the jack (still without brushes); advance maximum extension by 2-3 mm by adjusting the **maximum lowering microswitch** (the one furthest from the motor).
9. Reinstall the brushes and check that they are firmly hooked to the brush plate.
10. Adjust the brush **motor delay microswitch** (the one nearest the motor) so that the motor, while lowering, starts to operate when the brushes are 10-15 mm above the floor.
11. Check that the microswitch cam dowels are tight.
12. Reinstall the jack microswitch cover.

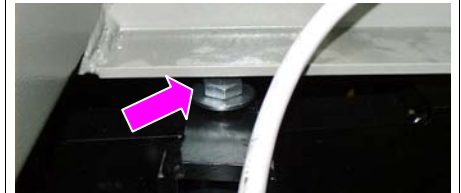
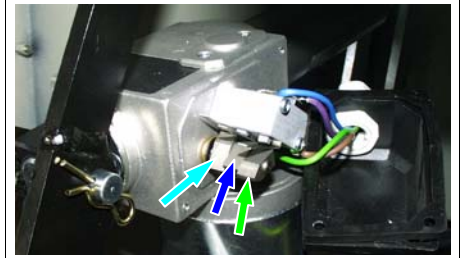

13. Adjust the brush base lowering microswitch: check that the all extended **spring**, with maximum brush base pressure (obtained by rotating the handwheel towards +), measures 274-276 mm between the centers of the two eyelets.



14. Bend the **external lowering microswitch lever** so that it trips in this position and keeps the microswitch pressed during the entire travel of the rocker arm (condition by which, during lifting, the motors remain off and the cam, when it moves, does not go past the trip point).
15. Check that 1 mm of clearance remains between the body of the microswitch and the lever with the control wheel when it is pressed by the cam.

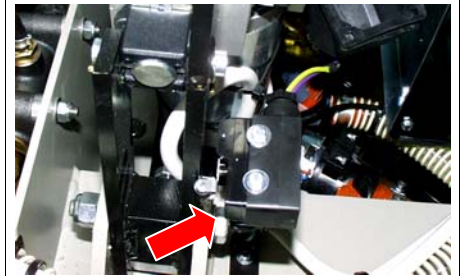

#### Adjustments and checks on the base

1. Lower the base and check the inclination of the brushes. They must touch the floor at the rear and be raised 5-7 mm in front. If necessary adjust them using the **lift arm supports**, sliding them in their slots.

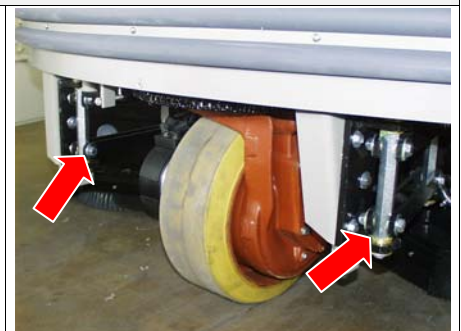

- Adjust the height of the lateral splash guards using the **M6 screws** so that, when moving forward, the rubber is inclined in the rear and barely touches the floor in front.

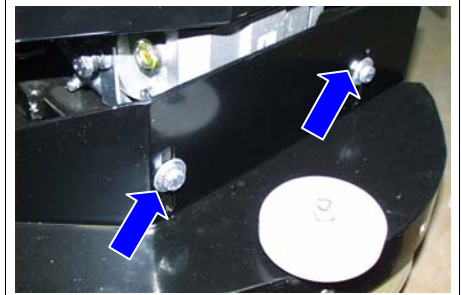

- Check the oil level in the reduction gears using the transparent **level plugs**. The oil must reach the red level marker. Use Shell Omala 460 (0.35 kg of oil). Top up through the upper plug.

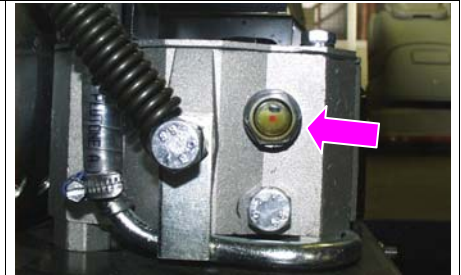

- Remove the protective casings and check the position of the brush motor **belts** after testing the machine. Check that belt tension is correct: loosen the screws that fasten the reduction gear. Tighten the nuts on the brush base and lock the screws in place.

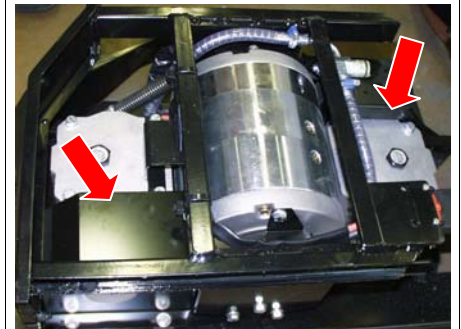

- Adjust extension of the two springs used to dampen any blows received by the base when it exits sideways. Do this so that the **tie-rod** exits 50-55 mm out from the frame.
- Lock the lock nut.



### Adjusting the sideways movement microswitches

- Lift the brush base.
- Dismantle the footrest platform.
- Remove the jack **microswitch** cover.
- Actuate sideways movement until the jack is all the way out and adjust the cam of the sideways movement microswitch (the one nearest the motor) so that the right base lift arms are at a distance of **2-3 mm** from the head of the arm support screw.
- Adjust the sideways return movement microswitch cam (the one furthest from the motor) so that the jack is 2-3 mm from the mechanical travel stop of the jack itself (all extended).
- Check tightening of the microswitch cam dowels and reinstall the jack's microswitch cover.

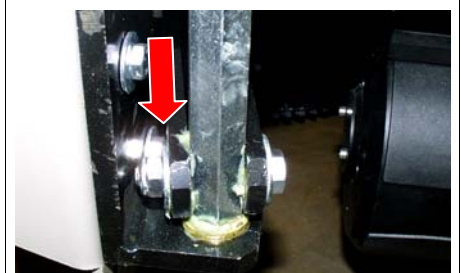
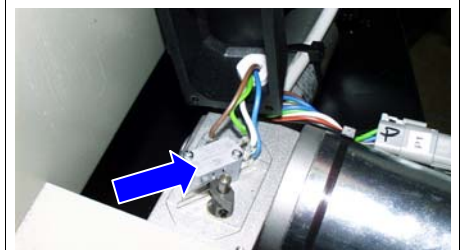

### Adjusting the sweeping unit

1. Remove both tanks.
2. Dismantle the jack's microswitch cover.
3. Adjust the maximum lowering microswitch cam (the most internal one) so that the jack is 2-3 mm from its mechanical travel stop (all extended).
4. Adjust the cam of the lift microswitch so that the tunnel is 8-10 mm distant from the two brackets that support the hand brake rocker arms (welded to the frame).
5. Check tightening of the microswitch cam dowels and reinstall the jack's microswitch cover.
6. Remove the sweeping unit's protective panel from the left part of the machine and adjust the screw inside the left shaft slot until you achieve a uniform brush footprint on the floor.
7. Adjust the two sweeping unit **support rods**, flush with their forks, so that the distance of the tunnel from the floor is **90-95 mm**.

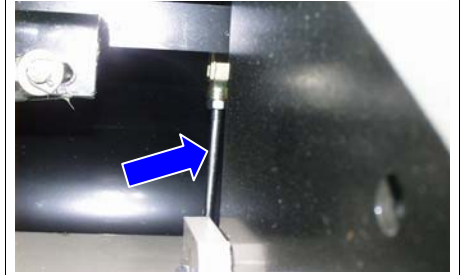

6. Adjust sweeping unit pressure: rotate the **large knob** placed in front of the unit so that the brushes generate a 10-15 mm footprint on the floor (the screw must jut out about 35 mm). Block using the **smaller knob**.

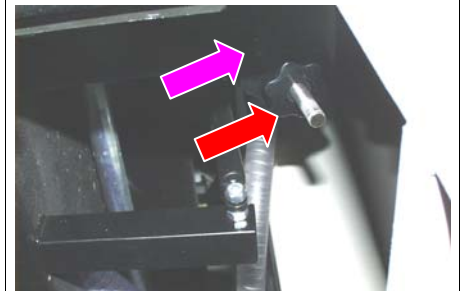

### Amperometric calibrating

**NOTE** : refer to the wiring diagram, dwg. 18.51.11 rev. 03).

1. Calibrating washing base motors: insert the ammeter clamp on the positive cable (No. 58) of the left base brush motor power supply (M5).
2. Lower the base, setting maximum pressure using the knob.
3. Press the brush switch to start rotating the brushes.
4. When the **signal lamp** related to the left base motor starts to flash check that the tester indicates 40-42 A. If necessary adjust the left base motor control card **trimmer** (advance flashing counterclockwise, delay flashing clockwise).
5. Increase pressure (pressing on the base) until the tester indicates 48-50 A and check that the motor automatically turns off after flashing 10-15 times.
6. Repeat these procedures for the right base motor, inserting the ammeter clamp on the positive cable (No. 56) of the motor supply (M4) and adjusting the right motor control card **trimmer** as necessary.
7. Seal the trimmers with enamel.
8. Calibrating the sweeping base motor: insert the ammeter clamp on the positive cable (No. 4) of power supply to the central brush motor (M10).
9. Lower the sweeping base, rotating the brushes by pressing the switch.
10. When the sweeping base motor signal lamp starts to flash check that the tester indicates 30-31 A. Adjust the **trimmer as necessary**.
11. Increase the pressure (pressing down on the base) until the tester indicates 33-34 A. Check that the motor turns off automatically after 10-15 flashes.
12. Calibrating the suction motor: insert the ammeter clamp on the positive cable (No. 4) of power supply to the large central brush motor (we use the large brush motor because we cannot increase suction motor amperes).
13. Detach the battery connector.
14. Move the negative cable (No. 3) of the large central brush from fuse F17 to fuse F18 in place of the negative cable (No. 5) of the suction motor.
15. Insert the battery connector.
16. Check, when the signal lamp related to the sweeping base motor starts to flash, that the tester indicates 33-35 A. Adjust the **trimmer** as necessary.
17. Increase pressure (pressing down on the base) until the tester indicates 38-40 A. Check that the motor turns off automatically after 10-15 flashes.
18. Put the negative cables back in their correct position.
19. Seal the trimmers with enamel.

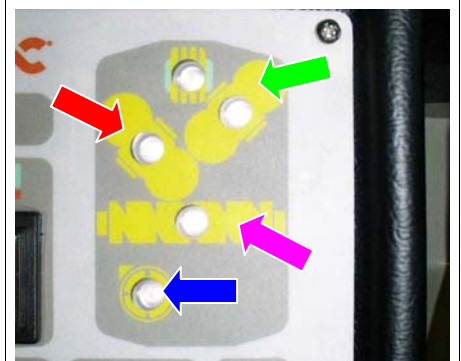
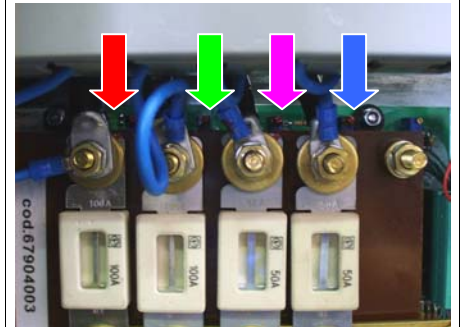

### Calibrating the suction motor float control card

1. Start the suction motor and check, by manually lifting the recovery *tank float*, that the motor stops in 4 seconds ( $\pm 1$  sec.). Adjust the card **trimmer** as necessary.
2. Seal the trimmer with enamel.

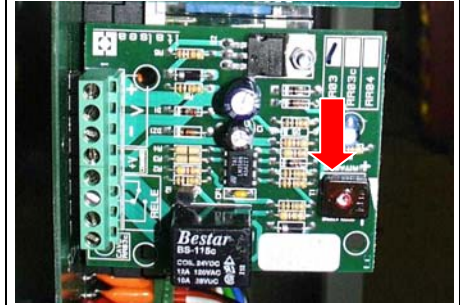

### Adjusting steering

1. Use the chain stretcher to restore proper chain tension:
  - loosen the lock nut;
  - tighten the **M8 screw** as necessary (try to turn steering all to the right and left, checking that it does not jam because of too much chain tension);
  - tighten the lock nut.
2. Check drive wheel clearance and tighten the screw as necessary. Remember that the lower taper roller bearing may seize if it is too tight. Re-test clearance and complete rotation.



### Brake inspection and adjustment

1. Check that wheels do not remain locked and that they brake simultaneously. Adjust the **tie-rods** as necessary. Tighten the lock nuts.
2. Restore correct hand brake, parking and emergency brake travels by adjusting the tie-rod: loosen the **lock nut** and screw the rod on its forks until the lever snaps two or three times. Re-tighten the lock nut.
3. Check and restore the level of **brake oil** (the brake oil tank is located in the front part of the machine).

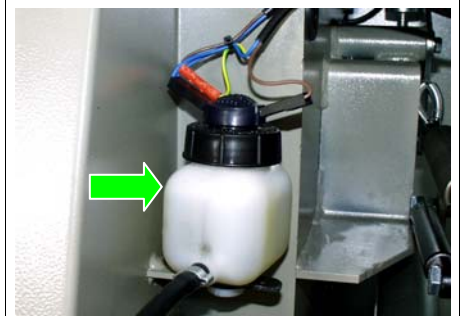
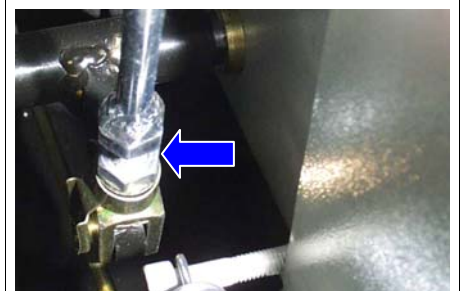
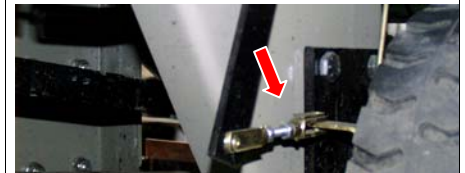

### Adjusting side bars

1. Adjusting the front part of the side bars: loosen the **M6 nut** and turn the screw while keeping the **tie-rod** firm (checking that the **guide** slides up and down) until the rubber barely touches the floor.

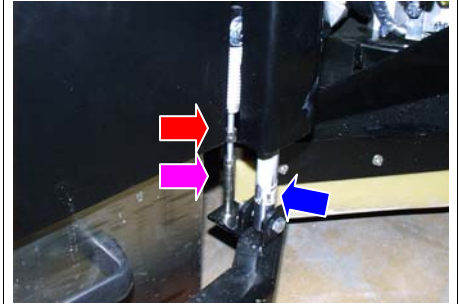

2. Adjusting the rear part of the side bars: adjust the **self-locking nut** so that the rubber is inclined. Lock in place with the needle.



### Testing the Plumbing System

1. Check the cleanliness and position of the **solution filter**.
2. Fill the solution tank with water and check for leaks.
3. Check hoses, **pump**, **solenoid valve** and water cock for leaks.
4. Check that the solution, when the cock is open, is constantly distributed on the floor and that it falls uniformly on the two bases and brushes.
5. Fill the recovery tank and check for leaks.
6. Check the drain tube and plug for leaks.

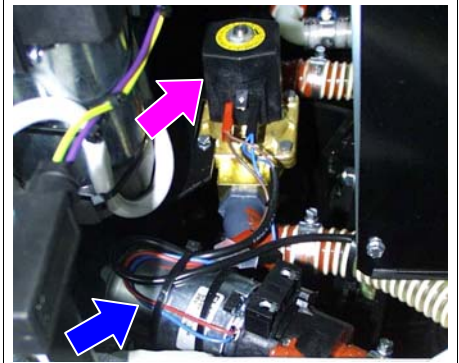
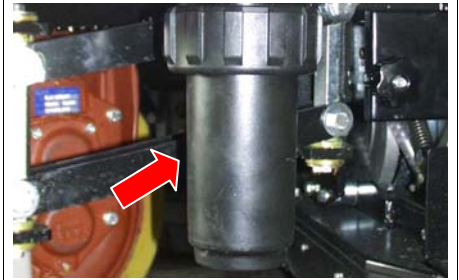

### Suction Test

1. Check that the **seals** on the suction motor are clean and efficient.
2. Check suction tubes and connections for cleanliness and leaks: squeegee, collection box and connection between the two (in the center of the tanks).

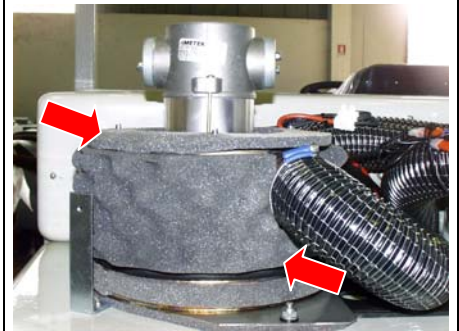

3. Check the cleanliness of the **filter** that protects the suction motor and the **filter** that protects the float, placed inside the recovery tank.

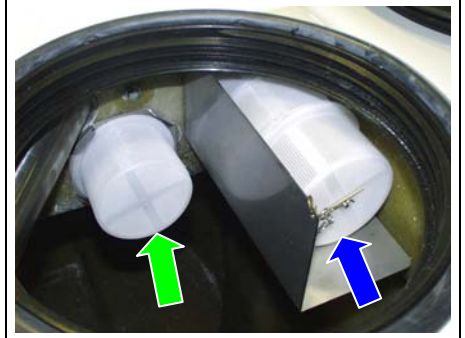

### Adjusting squeegee microswitches

1. Dismantle the cover of the jack microswitches.
2. Adjust the squeegee lift microswitch cam (the one nearest the motor) so that the top part of the squeegee connection is **185-190 mm** above the floor.
3. Adjust the squeegee lowering microswitch cam (the one furthest from the motor) so that the lowest part of the rocker arm is **20-22 mm** from the upper part of the squeegee connection.
4. Check tightening of microswitch cam dowels and reinstall the jack's microswitch cover.

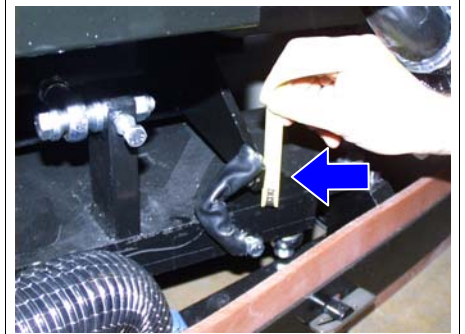

### Adjusting the squeegee

1. Loosen its lock **rings**.
2. Lift the support wheels, screwing them on the support so that the rubber has a uniform inclination on sides and in the center where it touches the floor.
3. Adjust the inclination of the squeegee by sliding **adjustment screws M12** in the slot so that the rubber is not too crushed against the ground but has an approximate 30° inclination. Block in place with the **M8 screws** and tighten the lock nut.

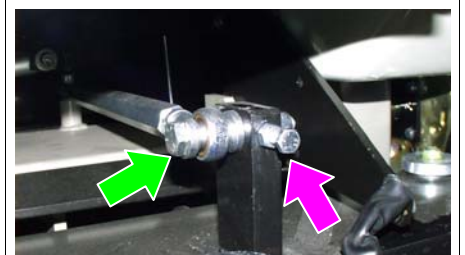
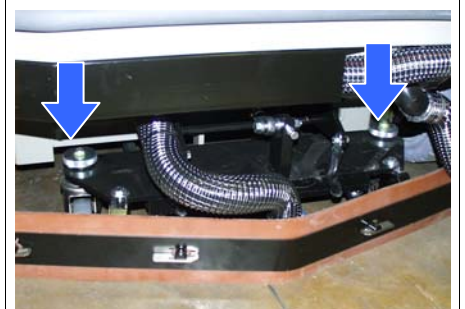



### Operational testing of the machine

- Check the efficiency of switches and signal lamps;
- Check the efficiency of the seat microswitch;
- Check the efficiency of the accelerator pedal;
- Check the efficiency of the base;
- Check the efficiency of the brush motor;
- Check the efficiency of manual and automatic operation by the sweeping unit;
- Check the efficiency of the sweeping unit motor;
- Check the efficiency of the sideways base movement jack;
- Check the efficiency of the solenoid valve;
- Check the efficiency of squeegee in manual and automatic operating modes;
- Check the efficiency of the suction motor;
- Check the efficiency of the emergency and parking brakes;
- Check the efficiency of the steering;
- Check the state of the batteries, terminals and cables;
- Check the efficiency of the horn;
- Check the efficiency of driving and flashing lights.

### Operational tests of the machine

- Fill the tanks with water and check for leaks.
- Check the plumbing system for leaks and that water drops uniformly on the brushes.
- Adjust the squeegee inclination and perform an operating test.
- Adjust the base inclination and perform an operating test.
- Check sideways movement and base retraction.
- Check the track left on the floor by the large brush and adjust by performing an operating test.
- Adjust the lateral base splash guards and lateral bars by performing an operating test.
- Check the efficiency of the seat microswitch.
- Check the efficiency of the seat position adjustment lever.
- Check that the water delivery selector operates properly.
- Check the efficiency of the knob that adjusts the pressure of the base brushes.
- Check the efficiency of the parking and emergency brakes: brake at maximum speed and check that all wheels lock simultaneously.
- Check that the machine, at maximum speed and with its tank full, stops in 125-130 cm when the accelerator pedal is released. If this is not the case then re-check console parameters and in particular "Release Braking" parameters.
- Check forward gear, reverse motion, acceleration and braking.

### Final Testing

Check all functions: washing, drying, forward gear, reverse motion and braking.